



**FEATURES**

- Wide range of application high flow valves for liquids, gaseous
- Hazardous environment
- Small poppet valve for tight shutoff
- Mountable in any position
- Dedicated to CPT Market

**TECHNICAL SPECIFICATION**

- Body material:** Brass UNI EN 12165 CW617N
- Armature tube:** Stainless Steel AISI 300 series
- Plungers:** Stainless Steel AISI 400 series
- Spring:** Stainless Steel AISI 300 series
- Ex d Housing in Aluminium die cast
- Media:** mineral oils, gasoline, diesel, fuel oils, air, inert gases, water, 134 a, R 404a
- Ex m Ambient temperature:** -20°C +50°C
- Ex m Fluid temperature:** -10°C +80°C with FKM seals  
-20°C + 80°C with H-NBR seals
- Ex d Ambient temperature:** -20°C +60°C
- Ex d Fluid temperature:** -10°C +140°C with FKM seals
- Design pressure PS:** 40 bar
- Protection class:** Ex m IP65 (complete with electric plug); Ex IP 67 (with cable gland)
- Electrical conformity:** IEC335

- Switching time:** 20 - 40 msec (depending on pressure conditions)
- (Conforme to Atex Directive 94/9/CE ATEX)
  - For S.V. 21A3..I  
II 2G Ex d II C T6
  - II 2D Ex tD A21 IP67 80°C
  - For S.V. 21A..Q  
II 2G Ex mb II T 4
  - II 2D Ex tD A21 IP 65 T130°C

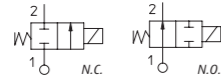

21A	2	QD	V	15	
Model valve	2= G 1/4	QD= N.C. Ex m	V= FKM	15	Orefice 10 <sup>-1</sup> mm
	3= G 3/8	KI= N.C. Ex d	F= H-NBR	20	
		ZI= N.C. Ex d		25	
				30	
				45	

B	D	A	08	012	C	S
B= 30mm Ø 13	D EN 175301-803	A= Class F	08= 8W	012= 12V 024= 24V 048= 48V 110= 110V 223= 220-230V	C= DC D= AC	S= Without Approval(*)

(\*) Ex d protection class when assembled with Ex housing

T	N	A	4X	024	D	4
T= 36mm Ø 14,5	N= 3 cables cm 300	A= Class F	4X= 7,2VA 5X= 9,13VA 05= 7,7-9,24VA 10= 10,1W	024= 24V 110= 110V 224= 220-240V	D= AC C= DC	4= Ex m T4

PIPE	Ø (mm)	Kv (l/min)	MAX VISCOSITY cSt (°E)	PRESSURE min	PRESSURE MAX MOPD (bar)				GAS CODE	CODE NTP	FLOW CURVE
					COIL TYPE						
					AC		DC				
B	T	B	T								

**Normally Closed Ex m**

G 1/8	1,5	1,4	12(2)	0	16	16	21A3QDV15	(Part numbering example add "N" at the 4th digit 21AN1Q)	1
	2	2	37(5)		16	16	21A3QDV20		1
	2,5	3,2	53(7)		14	9	21A3QDV25		1
	3	4	53(7)		10	6	21A3QDV30		1
	4,5	6,5	53(7)		5	2	21A3QDV45		1
G 1/4	1,5	1,4	12(2)	0	16	16	21A2QDV15	(Part numbering example add "N" at the 4th digit 21AN2Q)	1
	2	2	37(5)		16	16	21A2QDV20		1
	2,5	3,2	53(7)		14	9	21A2QDV25		1
	3	4	53(7)		10	6	21A2QDV30		1
	4,5	6,5	53(7)		5	2	21A2QDV45		1
	5,5	9	53(7)		3	1	21A2QDV55		1

**Normally Closed Ex d**

G 1/8	1,5	1,4	12(2)	0	30	18	21A3KIV15	(Part numbering example add "N" at the 4th digit 21AN1K)	2
	2	2	37(5)		22	16	21A3KIV20		2
	2,5	3,2	53(7)		14	9	21A3KIV25		2
	3	4	53(7)		10	6	21A3KIV30		2
G 1/4	1,5	1,4	12(2)	0	30	18	21A2KIV15	(Part numbering example add "N" at the 4th digit 21AN2K)	2
	2	2	37(5)		22	16	21A2KIV20		2
	2,5	3,2	53(7)		14	9	21A2KIV25		2
	3	4	53(7)		10	6	21A2KIV30		2

**Normally Opened Ex d**

G 1/8	1,5	1,4	12(2)	0	30	18	21A3ZIV15	(Part numbering example add "N" at the 4th digit 21AN1Z)	2
	2	2	37(5)		22	16	21A3ZIV20		2
	2,5	3,2	53(7)		14	9	21A3ZIV25		2
	3	4	53(7)		10	6	21A3ZIV30		2
G 1/4	1,5	1,4	12(2)	0	30	18	21A2ZIV15	(Part numbering example add "N" at the 4th digit 21AN2Z)	2
	2	2	37(5)		22	16	21A2ZIV20		2
	2,5	3,2	53(7)		14	9	21A2ZIV25		2
	3	4	53(7)		10	6	21A2ZIV30		2

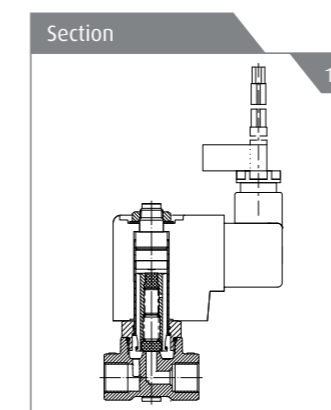

**REPAIR KIT**

For spare parts please consult our technical department

**Coil P/N Ex mb II T 4**

- RTNA4X024D4
- RTNA5X110D4
- RTNA05224DA
- RTNA10024C4

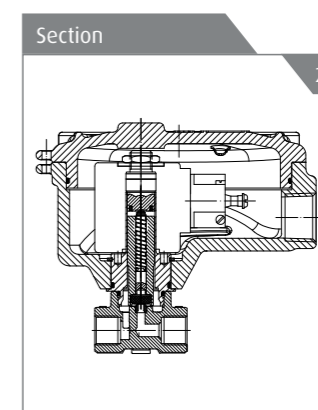

**REPAIR KIT**

For spare parts please consult our technical department

**ACCESSORIES**

Code P992219 Cable Gland (to be ordered separately)

**INSTALLATION**

- The solenoid valves can be mounted in any position
- Maintenance and instruction sheet available in each solenoid valve box
- Attention: for fuse selection please refer to the "Instruction sheet Atex products" delivered together with the valve
- Fixing holes
- Holes and threaded connections for panel fixing

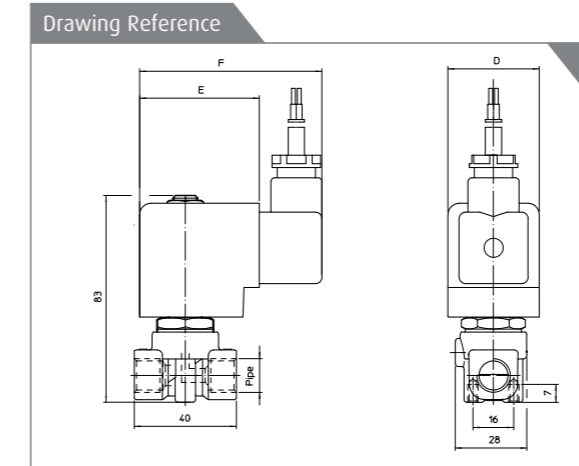

**Dimensional Table**

Figure	Coil Type	D mm	E mm	F mm
1	T	36	47	71,4

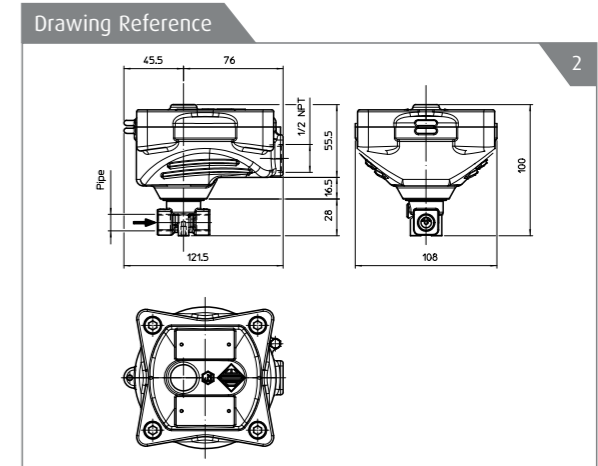

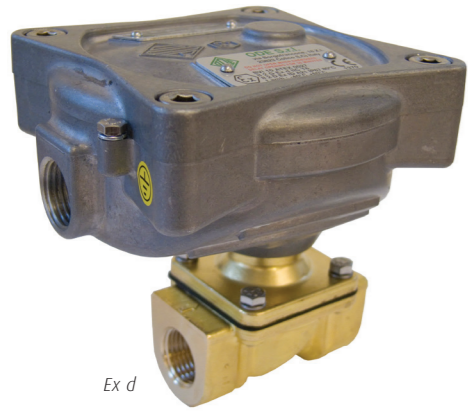

Ex d



**FEATURES**

- ▶ Wide range of application high flow valves for liquids, gaseous
- ▶ Hazardous environment
- ▶ Small poppet valve for tight shutoff
- ▶ Mountable in any position
- ▶ Dedicated to CPT Market

**TECHNICAL SPECIFICATION**

- ▶ **Body material:** Stainless Steel AISI 316
- ▶ **Armature tube:** Stainless Steel AISI 316
- ▶ **Plungers:** Stainless Steel AISI 400 Series
- ▶ **Spring:** Stainless Steel AISI 300 Series
- ▶ Ex d Housing in Aluminium die cast
- ▶ **Media:** air, inert gases, water, mineral oils, gasoline, diesel
- ▶ **Ambient temperature:** -20°C +60°C
- ▶ **Fluid temperature:** -10°C +80°C with NBR seals  
-10°C +140°C with FKM seals
- ▶ **Design pressure PS:** 16 bar
- ▶ **Electrical conformity:** IEC335
- ▶ (Conforme to Atex Directive 94/9/CE ATEX)  
II 2G Ex d II C T6  
II 2D Ex tD A21 IP67 80°C

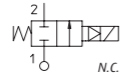

21H	3	KI	V	105		B	D	A	08	012	C	S
Model valve	3= G 3/8 - 3/8 NPT	KI= N.C.	V= FKM	150 160 200 250	Orifice 10 <sup>-1</sup> mm	B= 30mm Ø 13	D EN 175301-803	A= Class F	08= 8W	012= 12V	C= DC	S= Without approval(*)
	4= G 1/2 - 1/2 NPT		024= 24V							D= AC		
	5= G 3/4 - 3/4 NPT		048= 48V									
	6= G 1 - 1 NPT		110= 110V									
									223= 220-230V			

(\*) Ex d protection class when assembled with Ex housing

PIPE	Ø (mm)	Kv (l/min)	MAX VISCOSITY cSt (°E)	PRESSURE min	PRESSURE MAX MOPD (bar)				GAS CODE	CODE NTP	DRAWING REFERENCE	
					COIL TYPE							
					AC		DC					
G 3/8 3/8 NPT	15	40	12(2)	0	14		6			21IH3KIV150	21IN3KIV150-IH	1
G 1/2 1/2 NPT	16	50	12(2)	0	14		6			21IH4KIV160	21IN4KIV160-IH	1
G 3/4 3/4 NPT	20	60	12(2)	0	14		6			21IH5KIV200	21IN5KIV200-IH	1
G 1 1 NPT	25	140	12(2)	0	14		3			21IH6KIV250	21IN6KIV250-IH	1

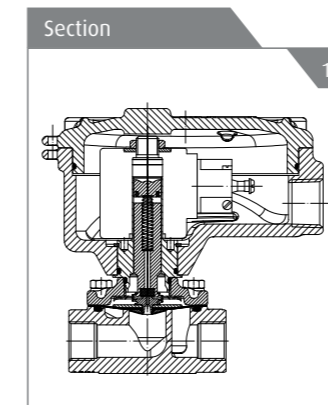

**REPAIR KIT**  
For spare parts please consult our technical department

**ACCESSORIES**  
Code P992219 Cable Gland (to be ordered separately)

**INSTALLATION**

- ▶ The solenoid valves can be mounted in any position
- ▶ Other port connections available on request
- ▶ Maintenance and instruction sheet available in each solenoid valve box
- ▶ Attention: for fuse selection please refer to the "Instruction sheet Atex products" delivered together with the valve
- ▶ Availability of repair kit and coils as spares.

**Drawing Reference**

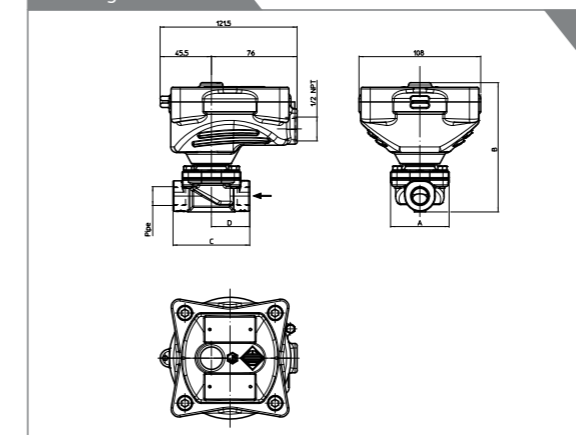

**Dimensional Table**

Figure	Pipe	A mm	B mm	C mm	D mm
1	G 3/8 3/8 NPT	52	114,5	68	34
	G 1/2 1/2 NPT				
	G 3/4 3/4 NPT	58	123	75	37,5
	G 1 1 NPT	65	131	90	45



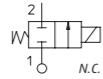

**FEATURES**

- ▶ Wide range of applications high flow valves for liquids, gaseous
- ▶ Reliable proven design with high flow
- ▶ Small poppet valve for tight shutoff
- ▶ Mountable in any position

**TECHNICAL SPECIFICATION**

- ▶ **Body material:** Stainless Steel AISI 316
- ▶ **Armature tube:** Stainless steel AISI 300 series
- ▶ **Plungers:** Stainless Steel AISI 400 series
- ▶ **Spring:** Stainless Steel AISI 300 series
- ▶ **Ex d Housing in Aluminium die cast**
- ▶ **Media:** mineral oils, gasoline, diesel, fuel oils, air, water, inert gases, 134 a, R 404a
- ▶ **Ex m Ambient temperature:** -20°C +50°C
- ▶ **Ex m Fluid temperature:** -10°C +80°C with FKM seals  
-20°C +80°C with H-NBR seals
- ▶ **Ex d Ambient temperature:** -40°C +60°C
- ▶ **Ex d Fluid temperature:** -10 +80°C with FKM seals
- ▶ **Design pressure PS:** 40 bar
- ▶ **Protection class:** Ex m IP65 (complete with electric plug); Ex d IP67 (with cable gland)
- ▶ **Electrical conformity:** IEC335

- ▶ (Conforme to Atex Directive 94/9/CE ATEX)
- For S.V. 21L..I  
II 2G Ex d II C T6
- II 2D Ex tD A21 IP67 80°C
- For S.V. 21L..Q  
II 2G Ex mb II T 4
- II 2D Ex tD  
A21 IP 65 T130°C



21L	1	QD	V	25	B	D	A	08	012	C	S
Model valve	1= G 1/8	QD= N.C.	V= FKM	25	U= 36mm Ø 13	D EN 175301-803	A= Class F	08= 8W	012= 12V	C= DC	S= Without approval(*)
	2= G 1/4	KI= N.C.	F= H-NBR	30					024= 24V	D= AC	
				40					048= 48V		
				55					110= 110V		
								223= 220-230V			

(\*) Ex d protection class when assembled with Ex housing

T	N	A	4X	024	D	4
T= 36mm Ø 14,5	N= 3 cables cm 300	A= Class F	4X= 7,2VA	024= 24V	D= AC	4= Ex m T4
			5X= 9,13VA	110= 110V		
			05= 7,7-9,24VA	224= 220-240V		
			10= 10,1W	024= 24V		

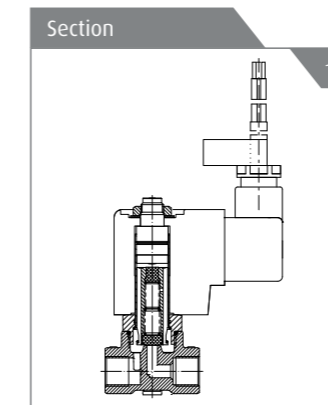

**REPAIR KIT**  
For spare parts please consult our technical department

**Coil P/N Ex mb II T 4**  
RTNA4X024D4  
RTNA5X110D4  
RTNA05224DA  
RTNA10024C4

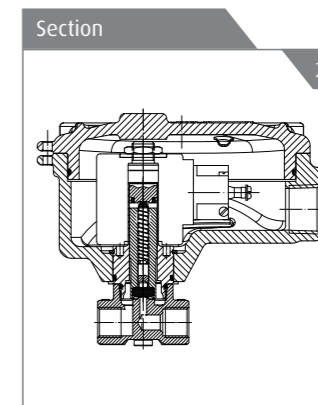

**REPAIR KIT**  
For spare parts please consult our technical department

**ACCESSORIES**  
Code P992219 Cable Gland (to be ordered separately)

PIPE	Ø (mm)	Kv (l/min)	MAX VISCOSITY cSt (°E)	PRESSURE min	PRESSURE MAX MOPD (bar)				GAS CODE	NTP CODE	DRAWING REFERENCE	
					COIL TYPE							
					AC		DC					
B	T	B	T									
<b>Normally Closed Ex m</b>												
G 1/8	25	3,2	53(7)	0	14			9		21L1QDV25	1	
	30	4	53(7)	0	10			6		21L1QDV30	1	
	40	5	53(7)	0	6		1,7			21L1QDV40	1	
G 1/4	25	3,2	53(7)	0	14			9		21L2QDV25	(Part numbering example add "N" at the 4th digit 21LN1QDV25)	
	30	4	53(7)	0	10			6		21L2QDV30		
	40	5	53(7)	0	6		1,7			21L2QDV40		
	55	9	53(7)	0	3,5			1		21L2QDV55		
<b>Normally Closed Ex d</b>												
G 1/4	25	3,2	53(7)	0	14	30	30	9	25	25	21L2KIV25	(Part numbering example add "N" at the 4th digit 21LN2KIV25)
	30	4	53(7)	0	10	25	25	6	17	20	21L2KIV30	
	40	5	53(7)	0	6	15	15	1,7	6	8	21L2KIV40	
	55	3,2	53(7)	0	14	30	30	9	25	25	21L2KIV55	

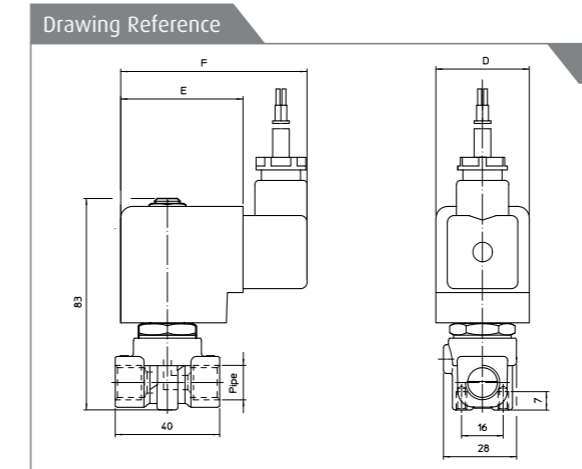

**Dimensional Table**

Figure	Coil Type	D mm	E mm	F mm
1	T	36	47	71,4

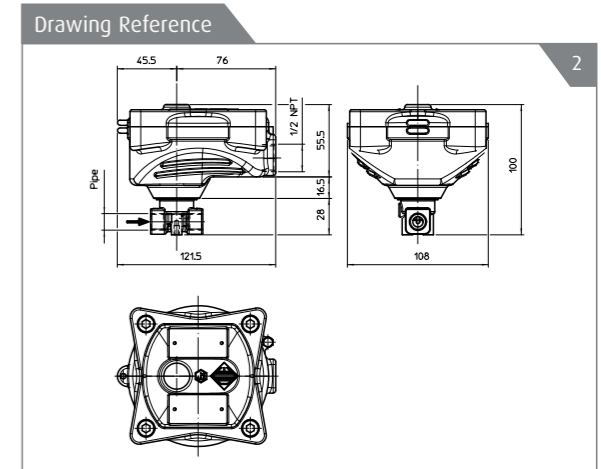

**INSTALLATION**

- ▶ The solenoid valves can be mounted in any position
- ▶ Maintenance and instruction sheet available in each solenoid valve box
- ▶ Attention: for fuse selection please refer to the "Instruction sheet Atex products" delivered together with the valve
- ▶ Fixing holes
- ▶ Holes and threaded connections for panel fixing





**FEATURES**

- ▶ Wide range of applications high flow valves for liquids, gaseous
- ▶ Reliable proven design with high flows
- ▶ Small poppet valve for tight shutoff
- ▶ Mountable in any position

**TECHNICAL SPECIFICATION**

- ▶ **Body material:** Brass UNI EN 12165 CW617N
- ▶ **Armature tube:** Stainless Steel AISI 300 series
- ▶ **Plungers:** Stainless Steel AISI 400 series
- ▶ **Spring:** Stainless Steel AISI 300 series
- ▶ **Ex d Housing in Aluminium die cast**
- ▶ **Media:** mineral oils, gasoline, diesel, air, inert gases, water, R 134a, R 404a
- ▶ **Ex m Ambient temperature:** -20°C + 50°C
- ▶ **Ex m Fluid temperature:** -10°C +80°C with FKM seals  
-20°C +80°C with H-NBR seals
- ▶ **Design pressure PS:** G 3/4 - 1 25 bar  
G 1 1/4 - G 2 16 bar
- ▶ **Ex d Ambient temperature:** -40°C +60°C
- ▶ **Ex d Fluid temperature:** -10°C +140°C with FKM seals
- ▶ **Design pressure PS:** 20 bar
- ▶ **Protection class:** Ex m IP 65 (complete with electric plug);

- Ex IP 67 (with cable gland)
- ▶ **Electrical conformity:** IEC335
- ▶ **Switching time:** 20-40 msec (depending on pressure conditions)
- ▶ (Conforme to Atex Directive 94/9/CE ATEX)
- For S.V. 21W..I  
II 2G Ex d II C T6  
II 2D Ex tD A21 IP67 80°C
- For S.V. 21W..Q  
II 2G Ex mb II T 4  
II 2D Ex tD  
A21 IP 65 T130°C



(Pressure Equipment Directive 97/23/CE) for S.V. 21WN7+21WN9 - 21W5+21W7

21WA	3	QD	V	130	B	D	A	08	012	C	S
Model valve	3= G 1/8	QD N.C. Ex m	V= FKM	130	B= 30mm Ø 13	D EN 175301-803	A= Class F	08= 8W	012= 12V	C= DC	S= Without approval(*)
	4= G 1/2		F= H-NBR	190					024= 24V	D= AC	
	5= G 3/4			250					048= 48V		
	6= G 1			350					110= 110V		
				400				223= 220-230V			

21W3	3	KI	B	190	T	N	A	4X	024	D	4	
Model valve	3= G 3/8 - 3/8 NPT	KI N.C. Ex d	B= NBR	190	T= 36mm Ø 14,5	N 3 cables cm 300	A= Class F	4X= 7,2 VA	024= 24V	D= AC	4= Ex m T4	
	4= G 1/2 - 1/2 NPT	ZI N.O. Ex d	E= EPDM	250				5X= 9,13 VA	110= 110V			
	5= G 3/4 - 3/4 NPT		F= H-NBR	350				05= 7,7-9,24 VA	224= 220-230V			
	6= G 1 - 1 NPT		V= FKM	400				10= 10W	024= 24V			C= DC
	7= G 1 1/4 - 1 1/4 NPT			500								
	8= G 1 1/2 - 1 1/2 NPT											
9= G 2 - 2 NPT												

(\*) Ex d protection class when assembled with Ex housing

PIPE	Ø (mm)	Kv (l/min)	MAX VISCOSITY cSt (°E)	PRESSURE min	PRESSURE MAX MOPD (bar)				GAS CODE	CODE NTP	FLOW CURVE
					COIL TYPE						
					AC		DC				
T	B	T	B								

**Normally Closed Ex m**

G 3/8	13	60	12(2)	0,2	16		16			21WA3QDV130	1
G 1/2	13	70	12(2)	0,2	16		16			21WA4QDV130	1
G 3/4	19	140	12(2)	0,2	16		16			21W3QDV190	1
G 1	25	190	12(2)	0,2	16		16			21W4QDV250	1
G 1 1/4	35	400	12(2)	0,2	16		16			21W5QDV350	1
G 1 1/2	40	520	12(2)	0,2	10		10			21W6QDV400	1
G 2	50	750	12(2)	0,2	10		10			21W7QDV500	1

**Normally Closed Ex d**

G 3/8	13	60	12(2)	0,2	-	16	-	16		21WA3KIB130	2
G 1/2	13	70	12(2)	0,2	-	16	-	16		21WA4KIB130	2
G 3/4	19	140	12(2)	0,2	-	16	-	16		21W3KIB190	2
G 1	25	190	12(2)	0,2	-	16	-	16		21W4KIB250	2
G 1 1/4	35	400	12(2)	0,2	-	10	-	10		21W5KIB350	2
G 1 1/2	40	520	12(2)	0,2	-	10	-	10		21W6KIB400	2
G 2	50	750	12(2)	0,2	-	10	-	10		21W7KIB500	2

**Normally Opened Ex d**

G 3/4	19	140	12(2)	0,2	16		16			21W3ZIB190	2
G 1	25	190	12(2)	0,2	-	16	-	16		21W4ZIB250	2
G 1 1/4	35	400	12(2)	0,2	-	10	-	10		21W5ZIB350	2
G 1 1/2	40	520	12(2)	0,2	-	10	-	10		21W6ZIB400	2
G 2	50	750	12(2)	0,2	-	10	-	10		21W7ZIB500	2

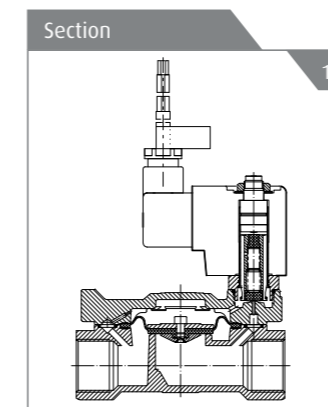

**REPAIR KIT**

For spare parts please consult our technical department

**Coil P/N Ex mb II T 4**

- RTNA4X024D4
- RTNA5X110D4
- RTNA05224DA
- RTNA10024C4

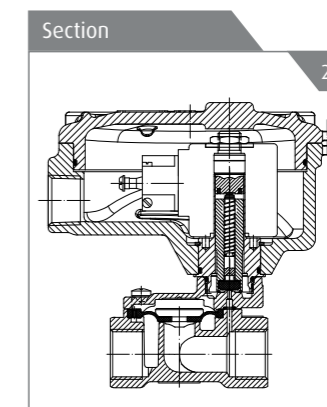

**REPAIR KIT**

For spare parts please consult our technical department

**ACCESSORIES**

Code P992219 Cable Gland (to be ordered separately)

**INSTALLATION**

- ▶ The solenoid valves can be mounted in any position
- ▶ Maintenance and instruction sheet available in each solenoid valve box
- ▶ Attention: for fuse selection please refer to the "Instruction sheet Atex products" delivered together with the valve
- ▶ Fixing holes
- ▶ Holes and threaded connections for panel fixing

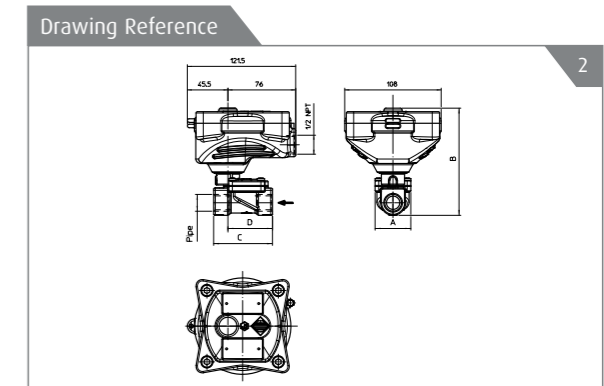
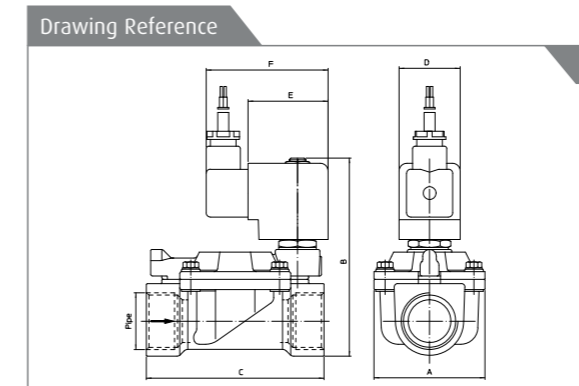

**Dimensional Table**

Figure	Pipe	Coil Type	A mm	B mm	C mm	D mm	E mm	F mm
1-2	G 3/8	B	40	120	60	47	-	-
		T		103		36		
	G 1/2	B	40	120	66	50	-	-
		T		103		36		
	G 3/4	B	65	128	104	89	-	-
		T		111		36		
	G 1	B	65	136	104	89	-	-
		T		118		36		
	G 1 1/4	B	98	153	144	125	-	-
		T		131		36		
	G 1 1/2	B	98	153	144	125	-	-
		T		131		36		
G 2	B	118	144	172	150	-	-	
	T		147		36			47



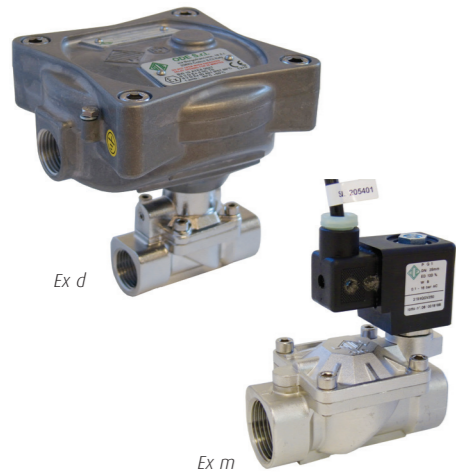

**FEATURES**

- ▶ Dedicate to CPT Market
- ▶ Explosion proof rate
- ▶ Reliable construction

**TECHNICAL SPECIFICATION**

- ▶ **Body material:** Stainless Steel AISI 316
- ▶ **Armature tube:** Stainless Steel AISI 300 series
- ▶ **Plungers:** Stainless Steel AISI 400 series
- ▶ **Spring:** Stainless Steel AISI 300 series
- ▶ **Ex d Housing in Aluminium die cast**
- ▶ **Media:** mineral oils, gasoline, diesel, fuel oils, air inert gases, water, 134 a, R 404a
- ▶ **Ex m Ambient temperature:** -20°C +50°C
- ▶ **Ex m Fluid temperature:** -10°C +80°C with FKM seals
- ▶ **Ex d Ambient temperature:** -20°C +60°C
- ▶ **Ex d Fluid temperature:** -10°C +80°C with H-NBR seals  
-10°C +140°C with FKM seals
- ▶ **Design pressure PS:** 25 bar
- ▶ **Protection class:** Ex m IP65 (complete with electric plug)  
Ex IP 67 (with cable gland)
- ▶ **Electrical conformity:** IEC335
- ▶ **Switching time:** 20-40 msec

- (depending on pressure conditions)
- ▶ (Conforme to Atex Directive 94/9/CE ATEX)  
For S.V. 21X2Q..  
II 2G Ex mb II T 4  
II 2D Ex tD  
A21 IP 65 T130°C  
For S.V. 21X2KI..  
II 2G Ex d II C T6  
II 2D Ex tD A21 IP67 80°C

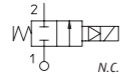

21X	2	QD	V	120	
Model valve	2= G 1/2 4= 1/2 NPT	QD N.C. Ex m	V= FKM	120 190 250	Orefice 10 <sup>-1</sup> mm
	3= G 3/4 5= 3/4 NPT	KI N.C. Ex d	F= H-NBR		
	4= G 1 6= 1 NPT				

B	D	A	08	012	C	S
B= 30mm Ø 13	D EN 175301-803	V= Class F	08= 8W	012= 12V 024= 24V 048= 48V 110= 110V 223= 220-230V	C= DC A= AC	S= Without Approval (*)

(\*) Ex d protection class when assembled with Ex housing

T	N	A	4X	024	D	4
T= 36mm Ø 14,5	N 3 cables cm 300	A= Class F	4X= 7,2VA 5X= 9,13VA 05= 7,7-9,24VA 10= 10,1W	024= 24V 110= 110V 224= 220-240V 024= 24V	D= AC C= DC	4= Ex m T4

PIPE	Ø (mm)	Kv (l/min)	MAX VISCOSITY cSt (°E)	PRESSURE min	PRESSURE MAX MOPD (bar)				GAS CODE	NTP CODE	DRAWING REFERENCE
					COIL TYPE						
					AC		DC				
B	T	B	T								
<b>Normally Closed Ex m</b>											
1/2	12	35	12(2)	0,1	16		16		21X2QDV120	21XN4QDV120	1
3/4	19	130	12(2)	0,1	16		16		21X3QDV190	21XN5QDV120	1
1	25	160	12(2)	0,1	16		16		21X4QDV250	21XN6QDV120	1
<b>Normally Closed Ex d</b>											
1/2	12	35	12(2)	0,1	20		20		21X2KIV120	21XN2KIV120	2
3/4	19	130	12(2)	0,1	16		16		21X3KIV190	21XN3KIV190	2
1	25	160	12(2)	0,1	16		16		21X4KIV250	21XN4KIV250	2

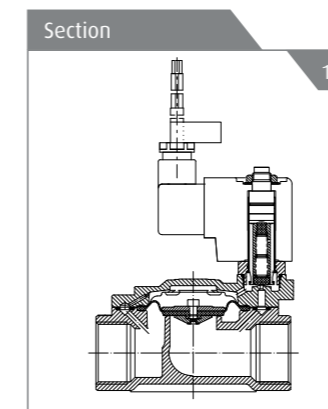

**REPAIR KIT**

For spare parts please consult our technical department

**Coil P/N Ex mb II T 4**

- RTNA4X024D4
- RTNA5X110D4
- RTNA05224DA
- RTNA10024C4

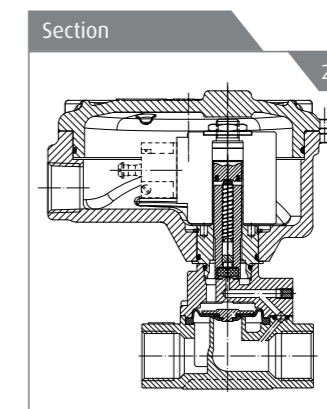

**REPAIR KIT**

For spare parts please consult our technical department

**ACCESSORIES**

Code P992219 Cable Gland (to be ordered separately)

**INSTALLATION**

- ▶ The solenoid valves can be mounted in any position
- ▶ Maintenance and instruction sheet available in each solenoid valve box
- ▶ Attention: for fuse selection please refer to the "Instruction sheet Atex products" delivered together with the valve
- ▶ Holes and threaded connections for panel fixing

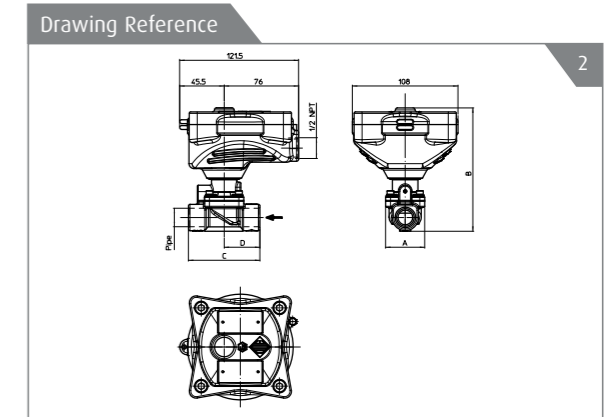
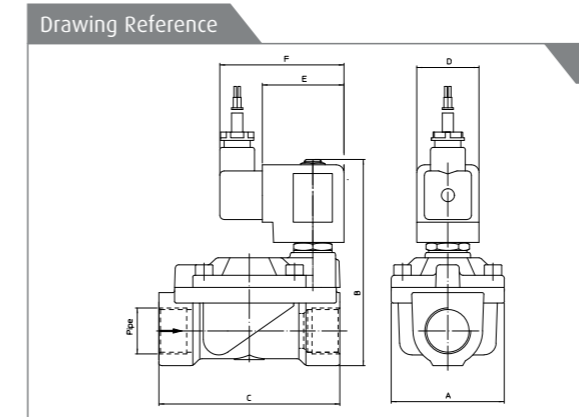

**Dimensional Table**

Figure	Pipe	Coil Type	A mm	B mm	C mm	D mm	E mm	F mm
1-2	G 1/2 1/2 NPT	B T	40	120 110	73	36,5 36	- 47	- 81
	G 3/4 3/4 NPT	B T	65	136 120	104	88,5 36	- 47	- 81
	G 1 1 NPT	B T	65	136 120	104	88,5 36	- 47	- 81





**FEATURES**

- Wide range of applications high flow valves for liquids, gaseous
- Reliable proven design with high flows
- Small poppet valve for tight shutoff
- Mountable in any position

**TECHNICAL SPECIFICATION**

- Body material:** Brass UNI EN 12165 CW617N
- Armature tube:** Stainless Steel AISI 300 series
- Plungers:** Stainless Steel AISI 400 series
- Spring:** Stainless Steel AISI 300 series
- Ex d Housing in Aluminium die cast
- Media:** mineral oils, gasoline, diesel, fuel oils, air inert gases, water, 134 a, R 404a
- Ambient temperature:** -20°C +50°C
- Ex m Fluid temperature:** -10°C +80°C with FKM seals  
-20°C +80°C with H-NBR seals
- Ex d Ambient temperature:** -20°C +60°C
- Ex d Fluid temperature:** -10°C +140°C with FKM seals
- Design pressure PS:** 40 bar
- Protection class:** Ex m IP 65 (complete with electric plug); Ex IP 67 (with cable gland)
- Electrical conformity:** IEC335

- Switching time:** 20-40 msec (depending on pressure conditions)
- (Conforme to Atex Directive 94/9/CE ATEX)
  - For S.V. 31A3EL.. II 2G Ex d II C T6
  - II 2D Ex tD A21 IP67 80°C
  - For S.V. 31A3P.. II 2G Ex mb II T 4
  - II 2D Ex tD A21 IP 65 T130°C

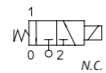

31A	3	PD	V	15	Orefice 10 <sup>3</sup> mm
Model valve	2= G 1/4	PD N.C. Ex m	V= FKM	15	
	3= G 3/8	EI N.C. Ex d	F= H-NBR	25 30	

B	D	A	08	012	C	S
B= 30mm Ø 13	D EN 175301-803	A= Class F	08= 8W	012= 12V 024= 24V 048= 48V 110= 110V 223= 220-230V	C= DC A= AC	S= Without Approval (*)

(\*) Ex d protection class when assembled with Ex housing

T	N	A	4X	024	D	4
T= 36mm Ø 14,5	N 3 cables cm 300	A= Class F	4X= 7,2VA 5X= 9,13VA 05= 7,7-9,24VA 10= 10,1W	024= 24V 110= 110V 224= 220-240V 024= 24V	D= AC C= DC	4= Ex m T4

PIPE	Ø (mm)	Kv (l/min)	MAX VISCOSITY cSt (°E)	PRESSURE min	PRESSURE MAX MOPD (bar)				GAS CODE	NTP CODE	FLOW CURVE
					COIL TYPE						
					AC		DC				

**Normally Closed Ex m** (\*) 3rd way exhaust= Ø 3 mm

G 1/8	1,5(*)	1,2	12(2)	0	15	15	31A3PDV15	(Part numbering example add "N" at the 4th digit 31AN1PD;31AN2PD)	1
	2(*)	2	37(5)		10	10	31A3PDV20		1
	2,5(*)	3	53(7)		6	6	31A3PDV25		1
	3(*)	3,5	53(7)		5	5	31A3PDV30		1
G 1/4	1,5(*)	1,2	12(2)	0	15	15	31A2PDV15		1
	2(*)	2	37(5)		10	10	31A2PDV20		1
	2,5(*)	3	53(7)		6	6	31A2PDV25		1
	3(*)	3,5	53(7)		5	5	31A2PDV30		1

**Normally Closed Ex d** (\*) 3rd way exhaust= Ø 3 mm

G 1/8	1(*)	0,45	12(2)	0	20	20	31A3EIV10	(Part numbering example add "N" at the 4th digit 31AN1EI;31AN2EI)	2
	1,5(*)	1,2	12(2)		15	15	31A3EIV15		2
	2(*)	2	37(5)		10	10	31A3EIV20		2
	2,5(*)	3	53(7)		6	6	31A3EIV25		2
G 1/4	1(*)	0,45	12(2)	0	20	20	31A2EIV10		2
	1,5(*)	1,2	12(2)		15	15	31A2EIV15		2
	2(*)	2	37(5)		10	10	31A2EIV20		2
	2,5(*)	3	53(7)		6	6	31A2EIV25		2
	3(*)	3,5	53(7)		5	5	31A2EIV30		2

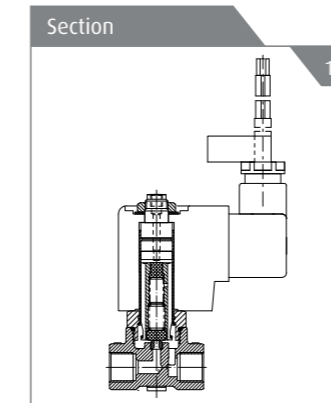

**REPAIR KIT**

For spare parts please consult our technical department

**Coil P/N Ex mb II T 4**

- RTNA4X024D4
- RTNA5X110D4
- RTNA05224DA
- RTNA10024C4

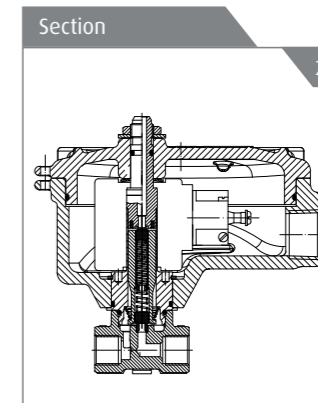

**REPAIR KIT**

For spare parts please consult our technical department

**ACCESSORIES**

Code P992219 Cable Gland (to be ordered separately)

**INSTALLATION**

- The solenoid valves can be mounted in any position
- Maintenance and instruction sheet available in each solenoid valve box
- Attention: for fuse selection please refer to the "Instruction sheet Atex products" delivered together with the valve
- Holes and threaded connections for panel fixing

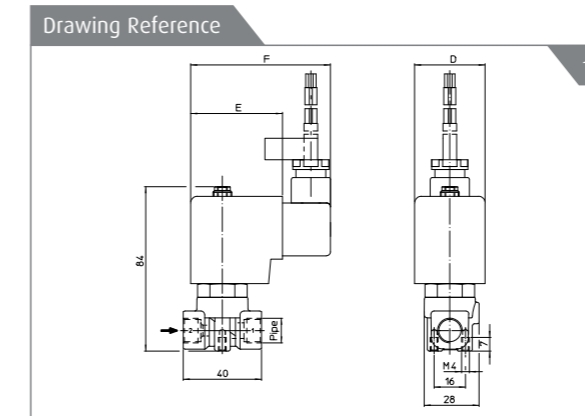

**Dimensional Table**

Figure	Coil Type	D mm	E mm	F mm
1	T	36	47	81

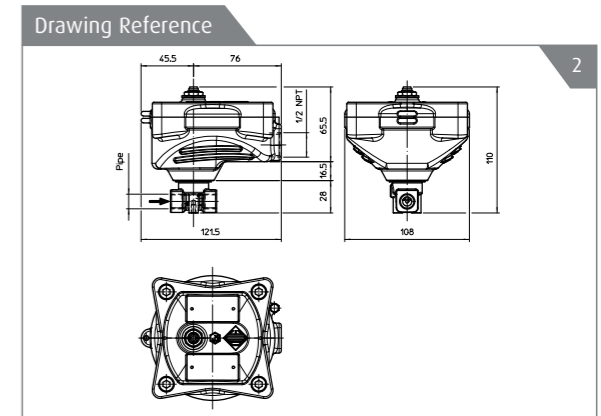

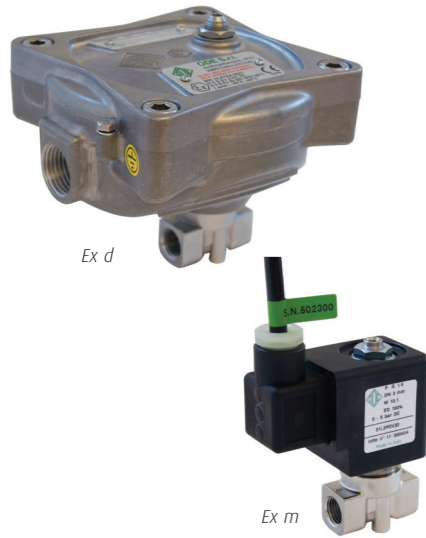

**FEATURES**

- ▶ Ideal for piloting
- ▶ High flow rate
- ▶ ATEX approval

**TECHNICAL SPECIFICATION**

- ▶ **Body material:** Stainless Steel AISI 316
- ▶ **Armature tube:** Stainless Steel AISI 300 series
- ▶ **Plungers:** Stainless Steel AISI 400 series
- ▶ **Spring:** Stainless Steel AISI 300 series
- ▶ **Ex d Housing in Aluminium die cast**
- ▶ **Media:** mineral oils, gasoline, diesel, fuel oils, air, water, inert gases, 134 a, R 404a
- ▶ **Ambient temperature:** -10°C +60°C (-10°C +80°C with class H coil, depending on coils)
- ▶ **Ex m Ambient temperature:** -20°C +50°C
- ▶ **Ex m Fluid temperature:** -10°C +80°C with FKM seals -20°C +80°C with H-NBR seals
- ▶ **Ex d Ambient temperature:** -40°C +60°C
- ▶ **Ex d Fluid temperature:** -10°C + 80°C with FKM seals
- ▶ **Design pressure PS:** 40 bar
- ▶ **Protection class:** Ex m IP 65 (complete with electric plug); Ex IP 67 (with cable gland)

- ▶ **Electrical conformity:** IEC335
- ▶ (Conforme to Atex Directive 94/9/CE ATEX)
  - For S.V. 31L..I
    - II 2G Ex d II C T6
    - II 2D Ex tD A21 IP67 80°C
  - For S.V. 31L..P
    - II 2G Ex mb II T 4
    - II 2D Ex tD
    - A21 IP 65 T130°C

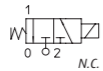

31L	1	PD	V	20	
Model valve	1= G 1/8	PD N.C. Ex m	V= FKM	20	Orefice 10 <sup>-3</sup> mm
	2= G 1/4	EI N.C. Ex d	F= H-NBR	30	

B	D	A	08	012	C	S
B= 30mm Ø 13	D EN 175301-803	A= Class F	08= 8W	012= 12V	C= DC	S= Without Approval (*)
				024= 24V	D= AC	
				048= 48V		
				110= 110V		
				223= 220-230V		

(\*) Ex d protection class when assembled with Ex housing

T	N	A	4X	024	D	4
T= 36mm Ø 14,5	N 3 cables cm 300	A= Class F	4X= 7,2VA	024= 24V	D= AC	4= Ex m T4
			5X= 9,13VA	110= 110V		
			05= 7,7-9,24VA	224= 220-240V		
			10= 10,1W	024= 24V		

PIPE	Ø (mm)	Kv (l/min)	MAX VISCOSITY cSt (°E)	PRESSURE min	PRESSURE MAX MOPD (bar)				GAS CODE	NTP CODE	DRAWING REFERENCE
					COIL TYPE						
					AC		DC				
B	T	B	T								
<b>Normally Closed Ex m</b> (*) 3rd way exhaust= Ø 3 mm											
G 1/8	20(*)	2	37(5)	0	10		10	(Part numbering example remove "N" at the 4 th digit 31L1PDV20)	31LN1PDV20	1	
G 1/8	20(*)	4	53(7)	0	10		10		31LN1PDV30	1	
G 1/4	20(*)	2	37(5)	0	10		10		31L2PDV20	31LN2PDV20	1
G 1/4	30(*)	4	53(7)	0	5		5		31L2PDV30	31LN2PDV30	1
<b>Normally Closed Ex d</b> (*) 3rd way exhaust= Ø 3 mm											
G 1/8	20(*)	2	37(5)	0	10		10		31L1EIV20	31LN1EIV20	2
G 1/8	20(*)	4	53(7)	0	5		5		31L1EIV30	31LN1EIV30	2
G 1/4	20(*)	2	37(5)	0	10		10		31L2EIV20	31LN2EIV20	2
G 1/4	30(*)	4	53(7)	0	5		5		31L2EIV20	31LN2EIV20	2

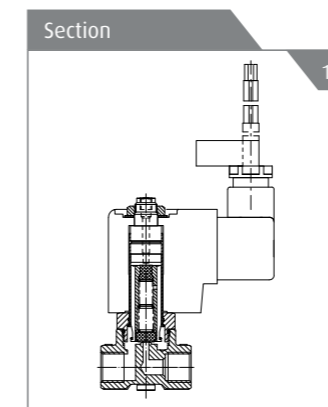

**REPAIR KIT**

For spare parts please consult our technical department

**Coil P/N Ex mb II T 4**

- RTNA4X024D4
- RTNA5X110D4
- RTNA05224DA
- RTNA10024C4

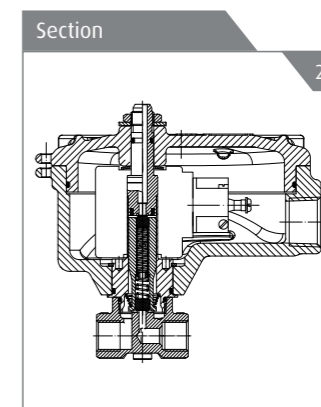

**REPAIR KIT**

For spare parts please consult our technical department

**ACCESSORIES**

Code P992219 Cable Gland (to be ordered separately)

**INSTALLATION**

- ▶ The solenoid valves can be mounted in any position
- ▶ Maintenance and instruction sheet available in each solenoid valve box
- ▶ Attention: for fuse selection please refer to the "Instruction sheet Atex products" delivered together with the valve
- ▶ Fixing holes
- ▶ Holes and threaded connections for panel fixing

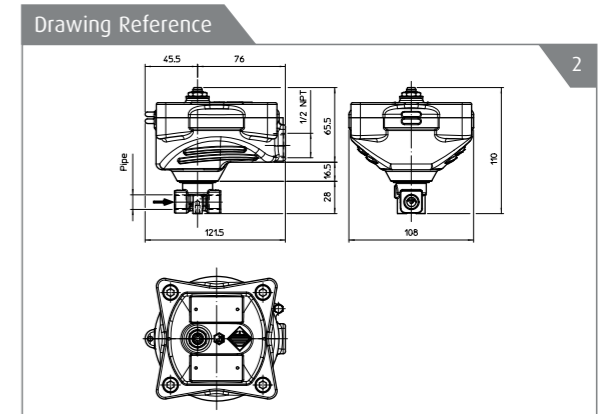
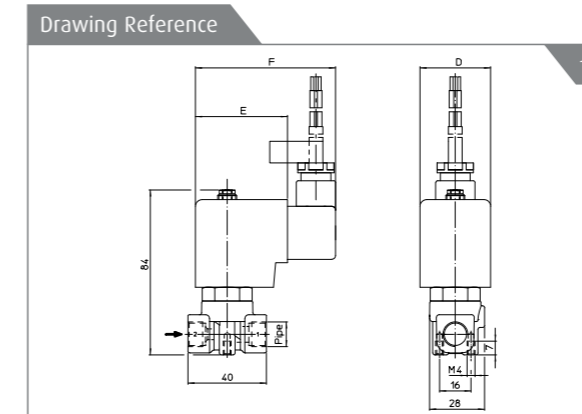

**Dimensional Table**

Figure	Coil Type	D mm	E mm	F mm
1	B	30	42	54

